

MIWA Intermittent Boiling System (MiBs) Boiling Operation Consulting for Batch Vacuum Pans

IMPROVED PROCESS PERFORMANCE

- INCREASED SUGAR YIELD PRODUCT / MASSECUTE = 2.3%
- INCREASED RECOVERY RATIO OF SOLID IN MASSECUTE = 2.1%
- REDUCED CRYSTALLIZATION TIME = 5%
- REDUCED RE-MELTING WATER CONSUMPTION
- REDUCED WASHING WATER CONSUMPTION

MERITS OF MiBs

Less False, Twin and Crowd Grain that leads to:

- IMPROVED COLOR VALUE
- REDUCED SUGAR DUST SO LESS DRYER FAN & COOLER TROUBLE
- BETTE SIEVE PROCESS
- BETTER PACKING SPEED

BOILING OPERATING CONSULTING

- HANDS ON GUIDANCE
- OPTIMIZED PARAMETER SETTINGS
- CORRECT BOILING TECHNIQUE IMPROVES MOTIVATION
- BETTER PRODUCT QUALITY
- INCREASED PRODUCTION VOLUME
- IMPROVED PLANT CAPACITY
- REDUCED COSTS

FOR INQUIRIES

MARUBENI PLANT ENGINEERING
MR YASUYOSHI YUSA
Email: Yusa-Y@marubeni.com
Tel: +81-3-3282-4841
Mobile: +81-90-6484-4879

CETI PHILIPPINES, INC.
MS. MARIA LOURDES DARIO
Mobile: +63-918-962-2514
Email: maria@cetiphilippines.com

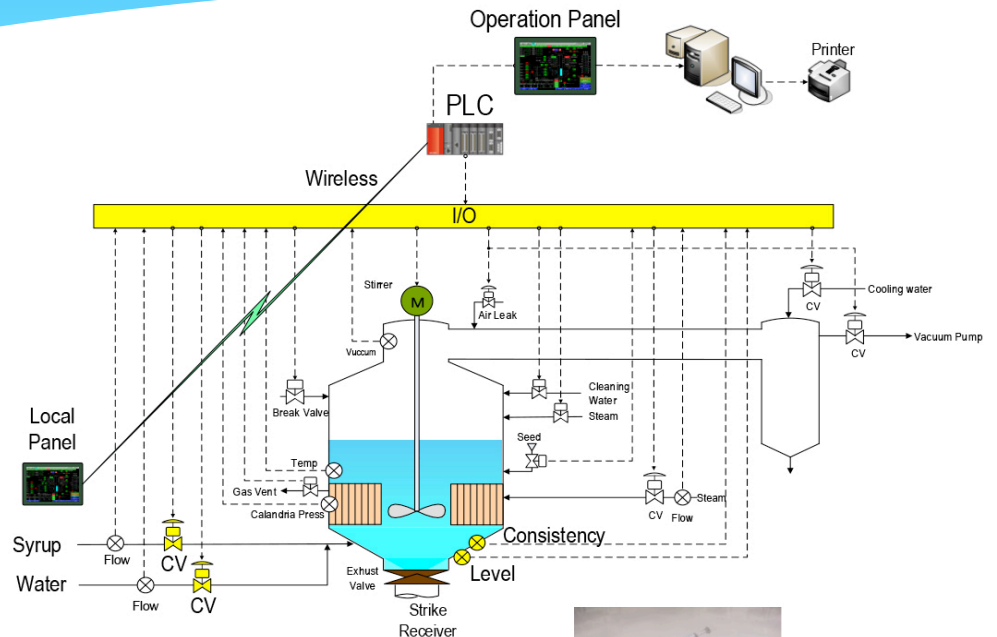

Consistency Meter

The MiBs and our Expertise, backed by our long history and rich experience in Boiling Operations Consulting, will help increase your Productivity & improve your Technical Capabilities in Boiling

